

MENHIR

ANCIENT INSPIRATION, CONTEMPORARY LOOK



CERAMICHE
SUPERGRES

Our idea

Menhir recupera la memoria delle quarziti più raffinate riproponendole nei progetti d'architettura contemporanea, fondendo l'estetica naturale senza tempo con la visione attuale del design e dell'abitare.

Menhir reinstates the memory of the most exquisite finest quartzites, making them available for contemporary architectural projects and blending their timeless natural aesthetic with today's vision of design and home living.

Menhir se réapproprié la mémoire des quartzites les plus raffinés en les proposant dans des projets architecturaux contemporains, mêlant l'esthétique naturelle intemporelle avec la vision actuelle du design et du foyer.

Menhir erinnert an feinsten Quarzit, dessen Optik gerne bei modernen Architektur-Projekten verwendet wird und dabei ein zeitloses natürliches Erscheinungsbild mit einer zeitgemäßen Sichtweise von Design und Wohnen verbindet.

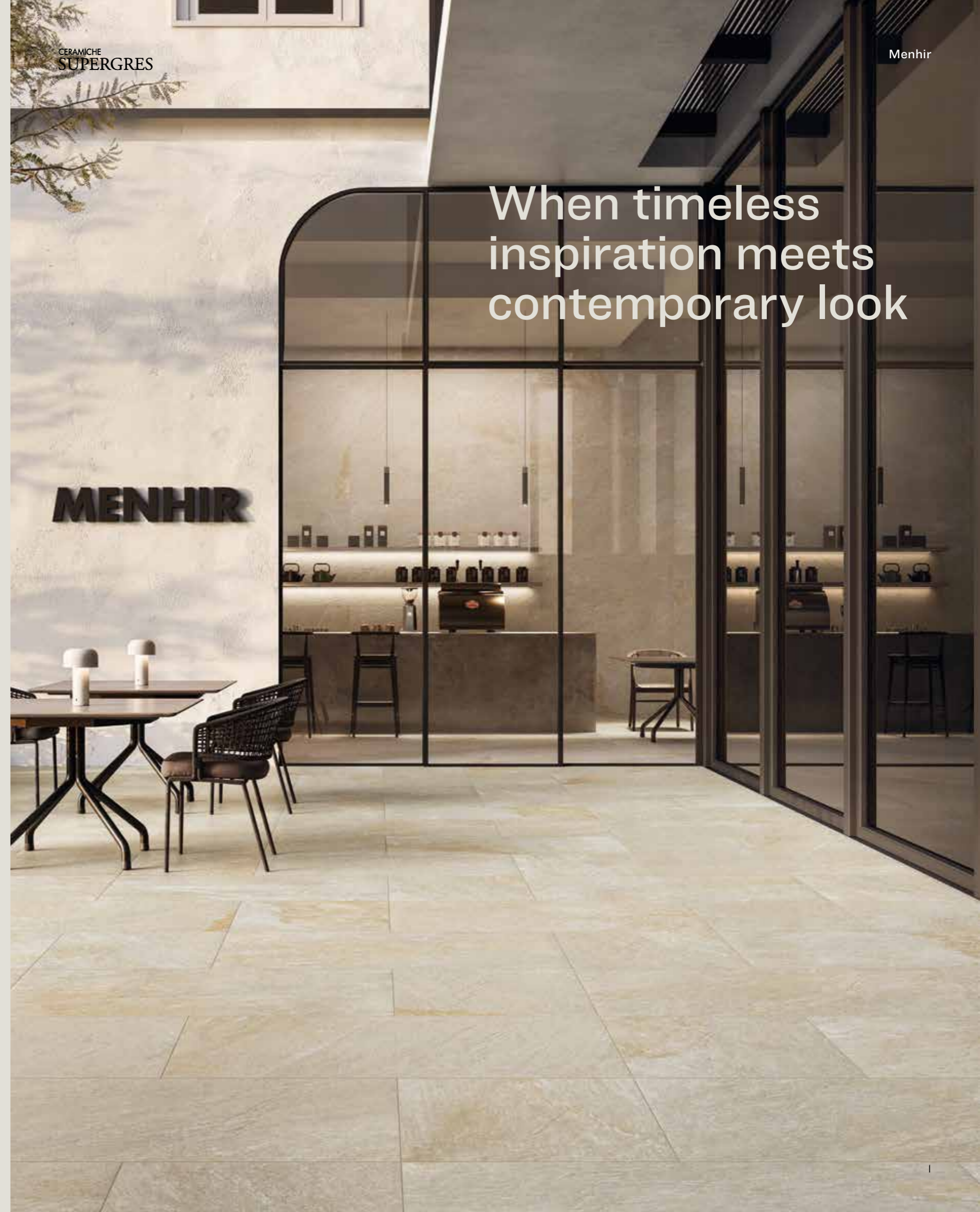

CERAMICHE
SUPERGRES

Menhir

When timeless
inspiration meets
contemporary look

Natural is minimal

Menhir, con la sua capacità di raccontare la forza e la bellezza della pietra naturale, interpreta le tendenze contemporanee attraverso scelte di arredo minimali, e integra la bellezza della natura con la funzionalità e versatilità del gres porcellanato.

With its powerful expression of the strength and beauty of natural stone Menhir fits perfectly into contemporary trends with its minimalist interior design offering and unites the beauty of nature with the convenience and versatility of porcelain gres.

Avec sa capacité à exprimer la force et la beauté de la pierre naturelle, Menhir interprète les tendances contemporaines à travers des choix d'ameublement minimalistes, et intègre la beauté de la nature avec la fonctionnalité et la polyvalence du grès cérame.

Menhir gelingt es, die Kraft und Schönheit des Natursteins wiederzugeben. Dieses Material interpretiert heutige Trends durch eine minimalistische Gestaltung und verbindet die Schönheit der Natur mit der Funktion und Vielseitigkeit von Feinsteinzeug.

CERAMICHE
SUPERGRES

Menhir

Minimal style,
natural mood



Range

5 colori

4 finiture

3 spessori

indoor

Anti slip soft touch R10 B | 9mm

60x120RT
sp.9mm

60x60RT
sp. 9mm

30x60RT
sp. 9mm

outdoor

Grip R11 C | 9mm

60x120RT
sp.9mm

60x60RT
sp. 9mm

30x60RT
sp. 9mm

T_20 R11 C | 20mm



60x120RT
sp.20mm

60x60RT
sp. 20mm

Strutturato R11 C | 8,5mm

22,5x45,3
sp.8,5mm

CERAMICHE
SUPERGRES

Menhir

The perfect
solution between
indoor and outdoor



Colors

Perfect balance
between graphic
and colors

Light

Sand

Greige

Grey

Wild



CERAMICHE
SUPERGRES

Menhir

Menhir riproduce fedelmente le sfumature, i dettagli e le caratteristiche cromatiche della quarzite naturale di qualità. Una gamma colori completa e fedele alla natura in grado di arricchire ogni progetto residenziale e commerciale con personalità e carattere.

Menhir accurately reproduces the varied shades, details and colour characteristics of high-quality natural quartzite. Its complete range of naturally occurring colours enhances every residential and commercial project with personality and character.

Menhir reproduit fidèlement les nuances, les détails et les caractéristiques chromatiques du quartzite naturel de qualité. Une gamme de couleurs complète et fidèle à la nature, en mesure d'enrichir tout projet résidentiel et commercial en conférant personnalité et caractère.

Menhir gibt die Farbnuancen, Details und chromatischen Eigenschaften von hochwertigem natürlichem Quarzit getreu wieder. Eine komplette, naturgetreue Farbpalette, die jedes Projekt mit Persönlichkeit und Charakter bereichern kann, egal ob es sich um Wohnprojekte oder gewerblich genutzte Flächen handelt.

Uses

La continuità tra interni ed esterni è una tendenza dell'architettura moderna che riflette il crescente bisogno di realizzare spazi abitativi bilanciati. Menhir risponde a questa esigenza offrendo soluzioni per tutti gli ambienti grazie alle finiture superficiali presenti in gamma.

Indoor-outdoor continuity is a modern architectural trend that reflects the growing need for balanced living-spaces. Menhir responds to this demand with solutions for all locations, thanks to wide array of surface finishes in its range.

La continuit  entre int rieur et ext rieur est une tendance de l'architecture moderne qui refl te le besoin croissant de r aliser des espaces de vie  quilibr s. Menhir r pond   cette exigence en offrant des solutions pour toutes les pi ces gr ce aux finitions de surface pr sentes dans la gamme.

Der flieende  bergang vom Innen- zum Auenbereich ist ein Trend in der modernen Architektur und spiegelt das wachsende Bed rfnis nach einem ausgeglichenen Wohnraum wider. Menhir reagiert auf dieses Bed rfnis, indem die Kollektion dank der erh ltlichen Oberfl chenfinishes f r jedes Ambiente eine L sung bietet.

CERAMICHE
SUPERGRES

Menhir

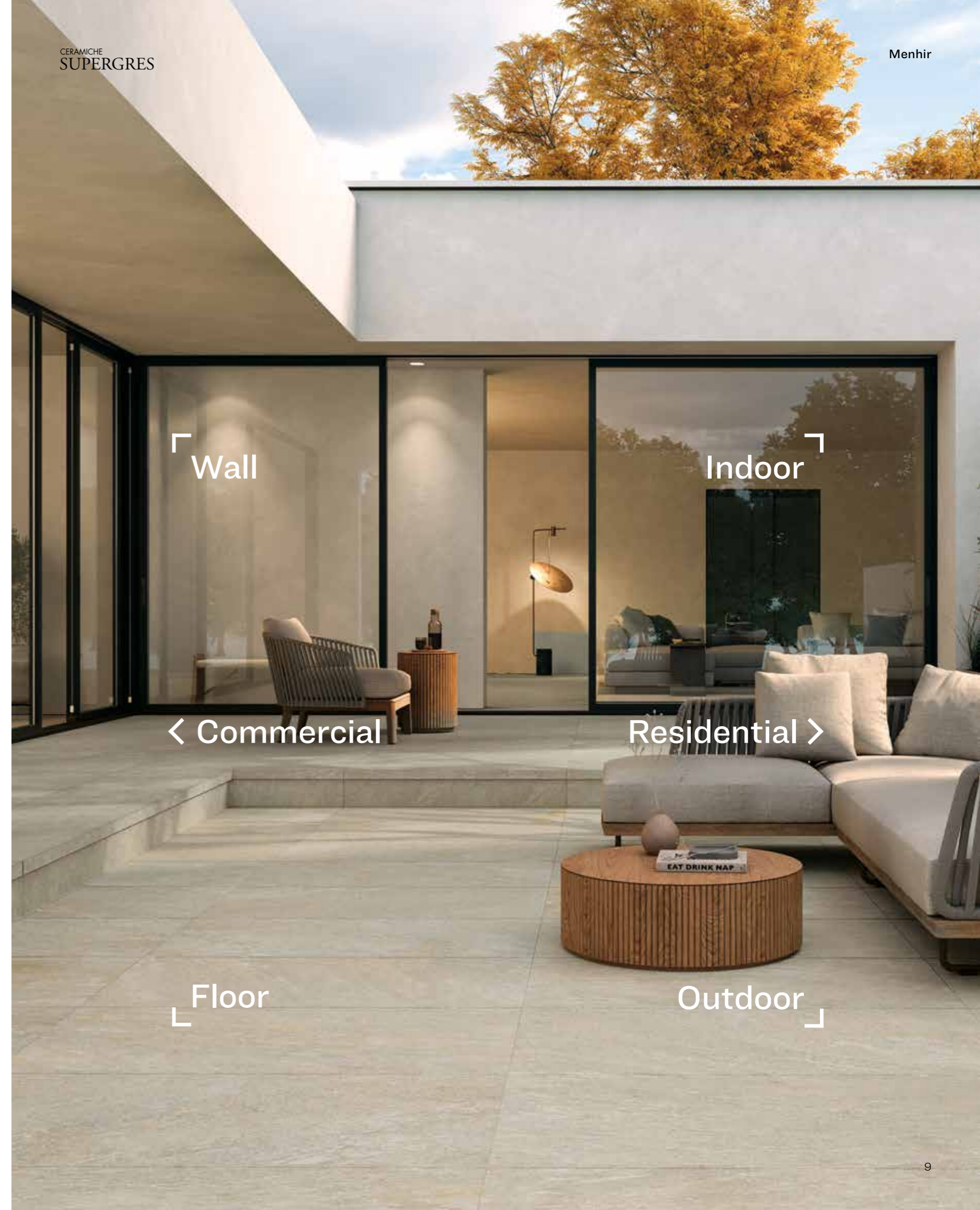

light |

Uno spazio accogliente, dove la luce gioca con l'eleganza. Light è il colore che conferisce un'atmosfera delicata e moderna grazie alle leggere venature naturali tono su tono che evocano la raffinatezza del materiale.

A welcoming space where light dialogues with elegance. Light is the colour that creates a delicate, modern mood, thanks to subtle, natural tone-on-tone shades variation that evokes all this material's refinement.

Un espace accueillant, où la lumière joue avec l'élégance. Light est la couleur qui confère une atmosphère délicate et moderne grâce aux légères veines naturelles ton sur ton qui évoquent le raffinement du matériau.

Ein gemütlicher Raum, in dem Licht mit Eleganz spielt. Light ist die Farbe, die dank der hellen, an die Raffinesse des Materials erinnernden Ton-in-Ton-Maserungen eine zarte und moderne Atmosphäre schafft.



Menhir light 60x120RT - 24"x48"



Menhir light 60x120RT - 24"x48"

greige |

Menhir offre la possibilità di progettare superfici senza soluzione di continuità, annullando i confini fra interno ed esterno. Greige è in perfetto equilibrio fra tonalità neutre e realismo materico, grazie a delicati passaggi di colore e a una leggera struttura superficiale.

Menhir enables the design of surfaces with seamless continuity, removing the borders between indoors and outdoors. Greige is the perfect blend of neutral shades and tactile realism, thanks to delicate colour transitions and a slightly textured surface.

Menhir offre la possibilité de concevoir des surfaces sans solution de continuité, supprimant les limites entre intérieur et extérieur. Greige est la synthèse parfaite entre nuances neutres et réalisme matérielle, grâce à des passages délicats de couleur et à une légère structure de surface.

Mit Menhir lassen sich kontinuierlich durchgehende Oberflächen schaffen, die Grenzen zwischen Innen- und Außenbereich scheinen sich aufzulösen. Greige ist die perfekte Synthese aus neutralem Farbton und materiellem Realismus, dank zarter Farbübergänge und einer leichten Oberflächenstruktur.





Menhir greige 60x120RT - 24"x48" | Menhir greige Mos. Ten 30x30RT - 12"x12"
Menhir greige grip 60x60RT - 24"x24" | Menhir greige grip 60x120RT - 24"x48"



Menhir greige grip 60x60RT - 24"x24" | Menhir greige grip 30x60RT - 12"x24"

wild |

Wild è caratterizzato da decisi contrasti cromatici e naturali variazioni superficiali. La luce naturale ne esalta la matericità e il movimento grafico, creando ambienti suggestivi e unici.

Wild is characterised by striking colour contrasts and a naturally varied surface.
Natural daylight emphasises its refined structure and patterning, creating unique, fascinating interiors.

Wild est caractérisé par des contrastes chromatiques prononcés et par des variations naturelles de surface.
La lumière naturelle en exalte l'aspect matériel et le mouvement graphique, créant des atmosphères suggestives et uniques.

Wild zeichnet sich durch deutliche Farbkontraste und natürliche Oberflächenvariationen aus.
Das natürliche Licht unterstreicht die Materialbetontheit und die grafische Bewegung und erzeugt ein suggestives und einzigartiges Ambiente.



Menhir wild 60x120RT - 24"x48"
Menhir wild grip 60x120RT - 24"x48"
Menhir wild Brick 30x60RT - 12"x48"



Menhir wild 60x120RT - 24"x48" | Menhir wild grip 60x120RT - 24"x48"
Menhir wild Brick 30x60RT - 12"x48"



Menhir wild 60x120RT - 24"x48" | Menhir wild grip 60x120RT - 24"x48"
Menhir wild Brick 30x60RT - 12"x48"



Menhir wild 22.5x45.3 - 9"x18"



Menhir wild 22.5x45.3 - 9"x18"



grey |

La versatilità di Menhir permette di ottenere continuità tra gli ambienti, grazie anche alla proposta in 20mm di spessore. Grey è in grado di creare spazi con una forte personalità attraverso la sua ricchezza grafica e i naturali contrasti cromatici. La durabilità del materiale assicura un risultato estetico e funzionale che resiste nel tempo.

Versatile Menhir allows continuity between different areas, supported by its offering in 20 mm thickness. With its rich patterning and natural colour contrasts, Grey is ideal for creating spaces with a strong personality. The material's durability ensures that its aesthetics and functional performance stand over time.

La polyvalence de Menhir permet d'obtenir une continuité entre les pièces, notamment grâce à la proposition en 20mm d'épaisseur. Grey est en mesure de créer des espaces ayant une forte personnalité à travers sa richesse graphique et ses contrastes chromatiques naturels. La durabilité du matériau garantit un résultat esthétique et fonctionnel qui résiste au fil du temps.

Auch dank der erhältlichen Plattenstärke von 20 mm lässt sich Kontinuität zwischen Innen- und Außenbereich erzielen. Die Version Grey ist in der Lage, durch ihren grafischen Reichtum und ihre natürlichen Farbkontraste Räumen eine starke persönliche Note zu verleihen. Die Strapazierfähigkeit des Materials gewährleistet ein ästhetisches, funktionelles und langlebiges Ergebnis.



Menhir grey T20 60x120RT - 24"x48" | Menhir grey 60x120RT - 24"x48"
Menhir grey T20 griglia 20x60RT - 8"x24" | Menhir grey T20 costa lucida 30x60RT - 12"x24" | Menhir grey T20 ang/est costa lucida 30x60RT - 12"x24"
Irony corten 120x278RT - 48"x109½" SERIE IRONY



Menhir grey 22.5x45.3 - 9"x18"
Love pearl T20 60x120RT - 24"x48" SERIE COLOVERS+



Menhir grey 22.5x45.3 - 9"x18"
Love pearl T20 60x120RT - 24"x48" SERIE COLOVERS+



Menhir grey 60x120RT - 24"x48"
Menhir grey pattern 39.5x39.5 RT 15,5"x15.5"
Irony lead 120x278RT 48"x109 1/2" SERIE IRONY

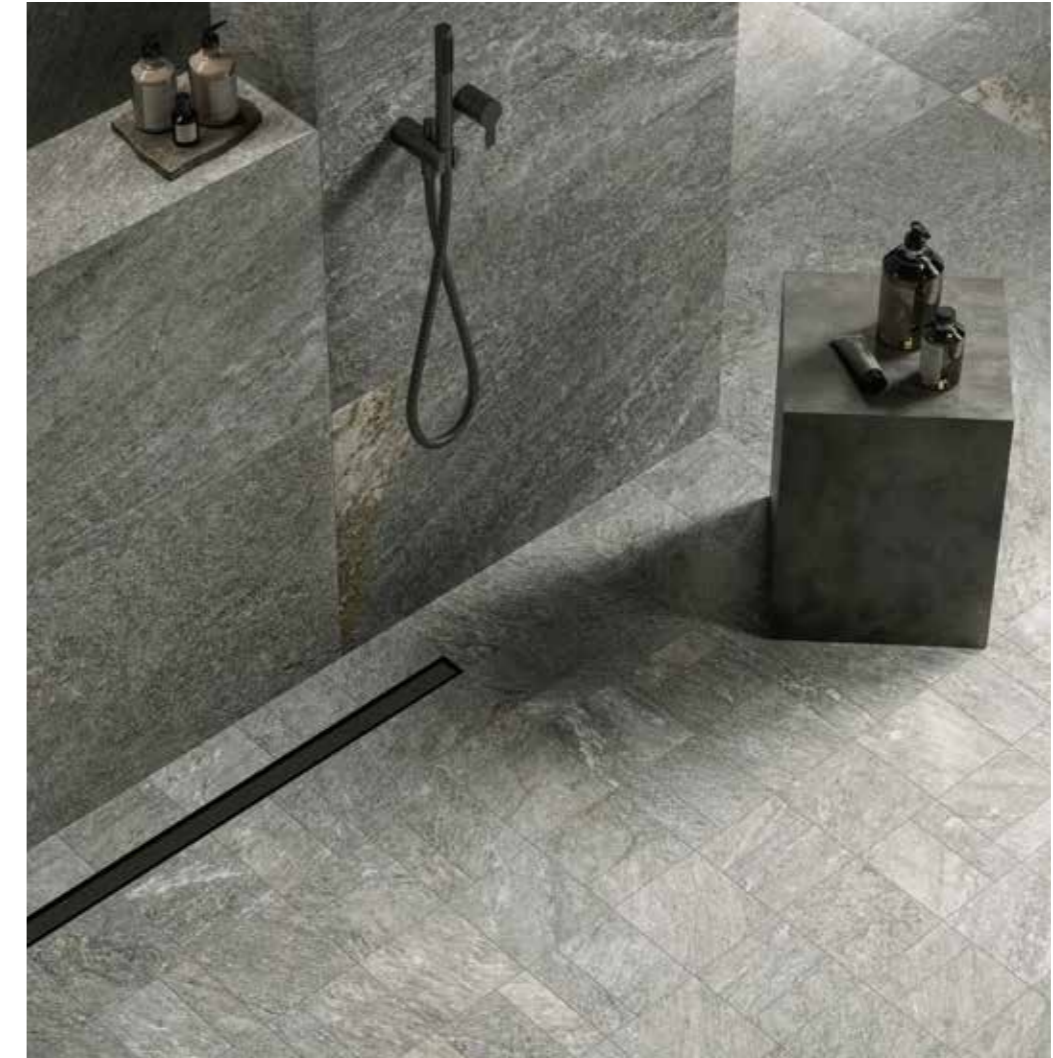

Menhir grey 60x120RT - 24"x48"
Menhir grey pattern 39.5x39.5 RT 15,5"x15.5"
Irony lead 120x278RT 48"x109 1/2" SERIE IRONY

sand |

Spazi accoglienti, curati nei dettagli, linee pulite e arredi essenziali. Menhir con le tonalità luminose e calde del colore Sand crea un'atmosfera serena e rilassante anche in contesti commerciali.

Inviting locations, meticulously styled in every detail, with immaculate lines and simple furnishings.
With the warm, radiant hues of its Sand colour, Menhir creates a relaxed, serene atmosphere even in commercial contexts.

Des espaces accueillants aux détails soignés et aux lignes épurées, et des ameublements essentiels.
Avec les nuances lumineuses et chaudes de la couleur Sand, Menhir crée une ambiance sereine et relaxante même dans les contextes commerciaux.

Einladende Räumlichkeiten mit Liebe zum Detail, klaren Linien und essentiellen Einrichtungsgegenständen.
Mit den hellen und warmen Nuancen der Farbe Sand schafft Menhir auch in gewerblich genutzten Räumen eine ruhige und entspannende Atmosphäre.

Menhir sand 60x120RT - 24"x48"
Irony lead 120x1278RT - 48"x109½" SERIE IRONY



Menhir sand grip 60x120RT - 24"x48"
Menhir sand grip 60x60RT - 24"x24"





Menhir sand T20 60x120RT - 24"x48"



Menhir sand T20 60x120RT - 24"x48"

light



60x120RT - 60x60RT - 30x60RT | ANTI SLIP SOFT TOUCH R10 B | 9mm
60x120RT - 60x60RT - 30x60RT | GRIP R11 C | 9mm

GRES PORCELLANATO | PORCELAIN TILES

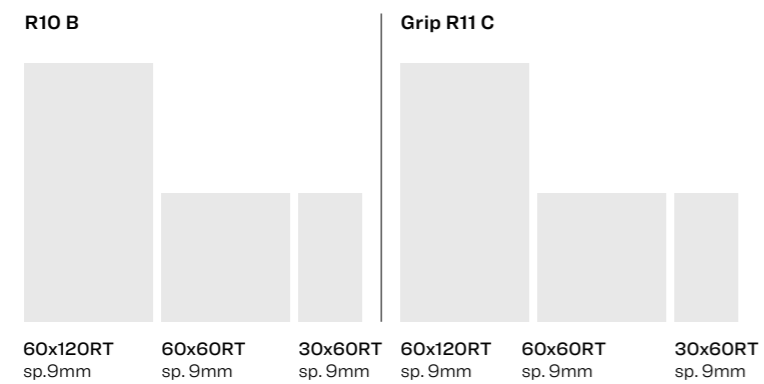

sand



60x120RT - 60x60RT - 30x60RT | ANTI SLIP SOFT TOUCH R10 B | 9mm
60x120RT - 60x60RT - 30x60RT | GRIP R11 C | 9mm
22,5x45,3 | R11 C | 8,5mm
60x120RT - 60x60RT | T_20 - R11 C | 20mm



GRES PORCELLANATO | PORCELAIN TILES

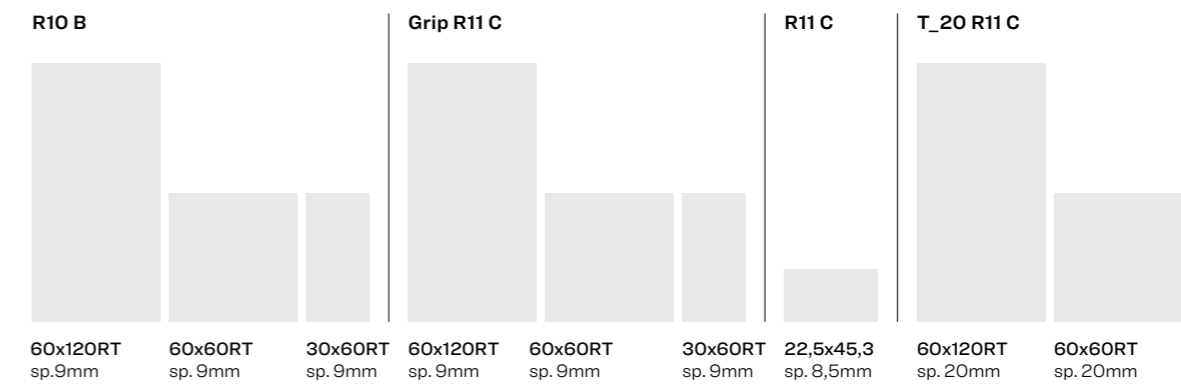

grey



60x120RT - 60x60RT - 30x60RT | ANTI SLIP SOFT TOUCH R10 B | 9mm
 60x120RT - 60x60RT - 30x60RT | GRIP R11 C | 9mm
 22,5x45,3 | R11 C | 8,5mm
 60x120RT - 60x60RT | T_20 - R11 C | 20mm **T_20**

GRES PORCELLANATO | PORCELAIN TILES

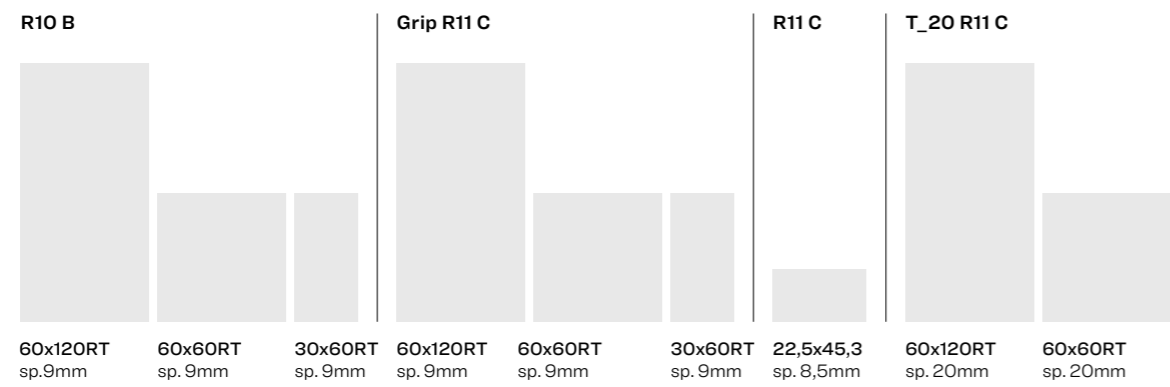

greige



60x120RT - 60x60RT - 30x60RT | ANTI SLIP SOFT TOUCH R10 B | 9mm
 60x120RT - 60x60RT - 30x60RT | GRIP R11 C | 9mm
 22,5x45,3 | R11 C | 8,5mm
 60x120RT - 60x60RT | T_20 - R11 C | 20mm **T_20**

GRES PORCELLANATO | PORCELAIN TILES

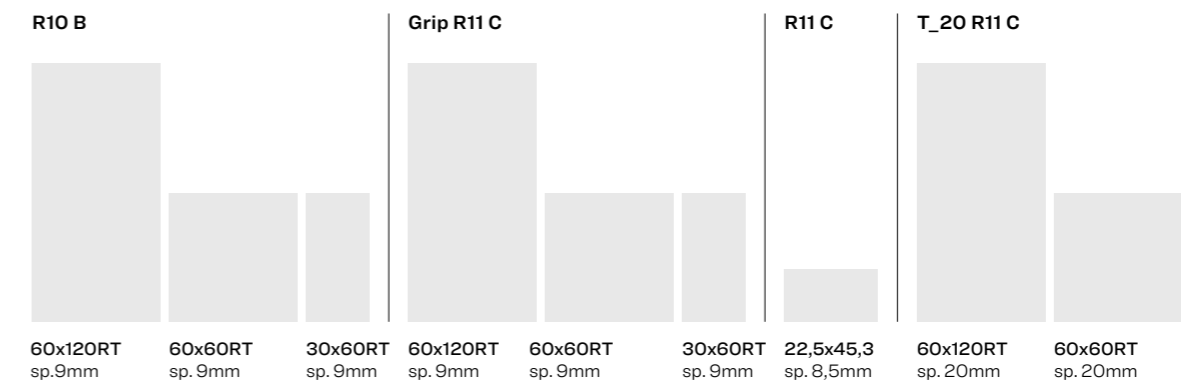

wild



60x120RT - 60x60RT - 30x60RT | ANTI SLIP SOFT TOUCH R10 B | 9mm
 60x120RT - 60x60RT - 30x60RT | GRIP R11 C | 9mm
 22,5x45,3 | R11 C | 8,5mm

GRES PORCELLANATO | PORCELAIN TILES

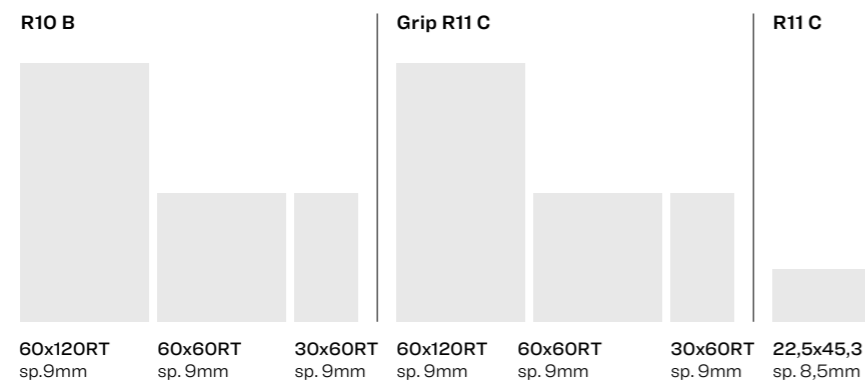

mosaici

GRES PORCELLANATO | PORCELAIN TILES

BRICK light



BRICK sand



BRICK greige



BRICK
9 mm \pm 30x60RT



BRICK grey



BRICK wild

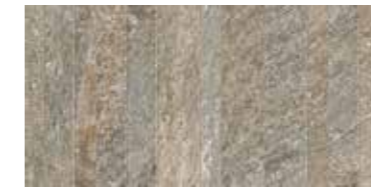

TEN light



TEN sand



TEN greige

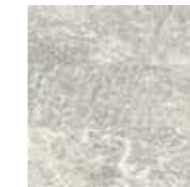

TEN grey



TEN wild



TEN
9 mm \pm 30x30RT



PATTERN light



PATTERN sand



PATTERN greige



PATTERN grey



PATTERN wild



PATTERN
9 mm \pm 39,5x39,5RT



light



sand



greige



grey



wild

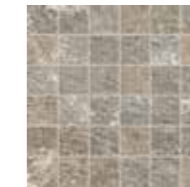

MOSAICO
9 mm \pm 30x30RT



22,5x45,3 - 9"x18"

sand



wild



grey



greige



GRES PORCELLANATO | PORCELAIN TILES

22,5x45,3 | R11 C | 8,5mm



22,5x45,3
sp. 8,5mm



T_20

sand



greige



grey



GRES PORCELLANATO | PORCELAIN TILES
60x120RT - 60x60RT | T_20 - R11 C | 20mm



60x120RT
sp.9mm



60x60RT
sp.9mm

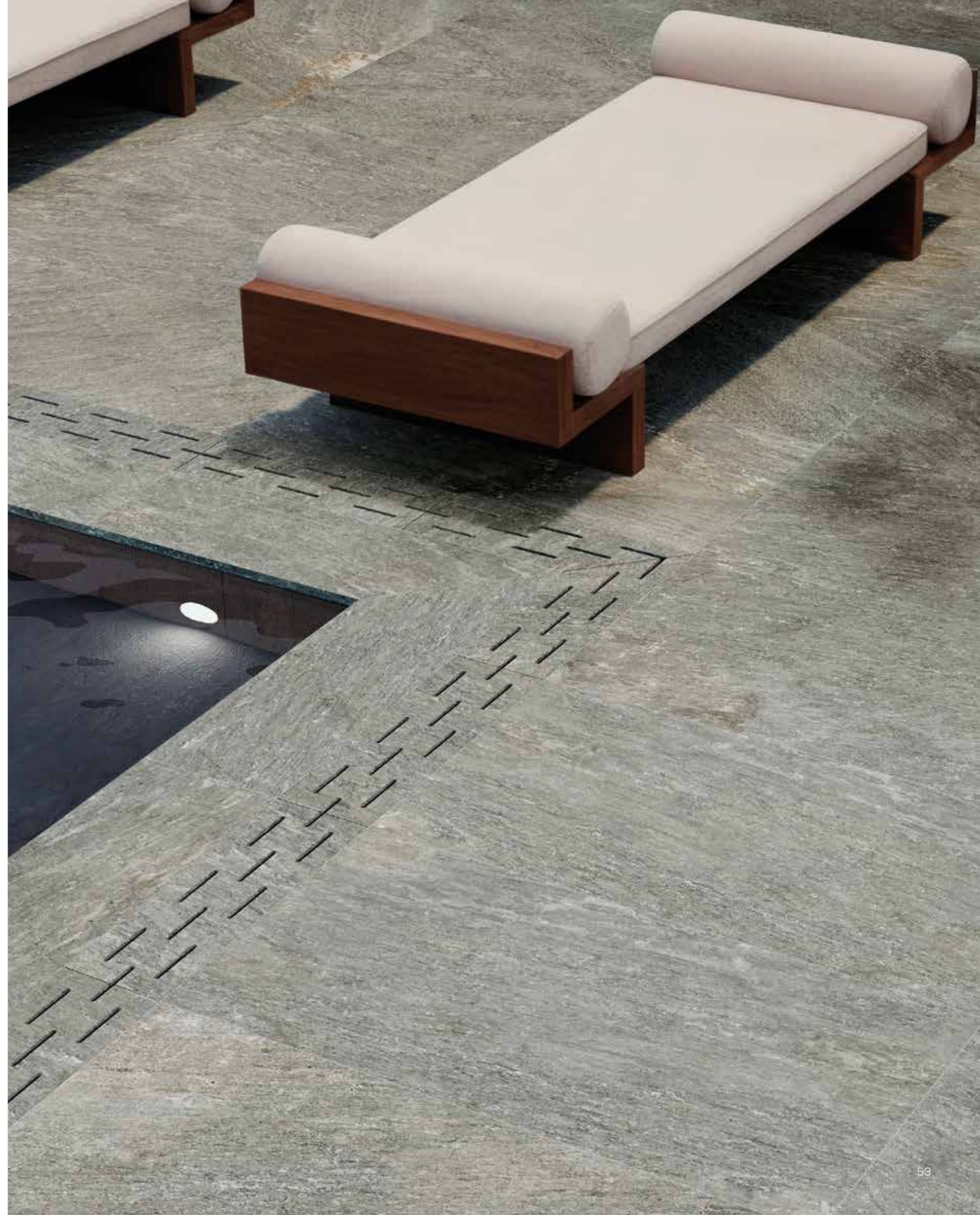

MENHIR

GRES PORCELLANATO | PORCELAIN TILES | GRÈS CÉRAMÉ | FEINSTEINZEUG

pezzi speciali | special tiles | pièces spéciales | Formteile

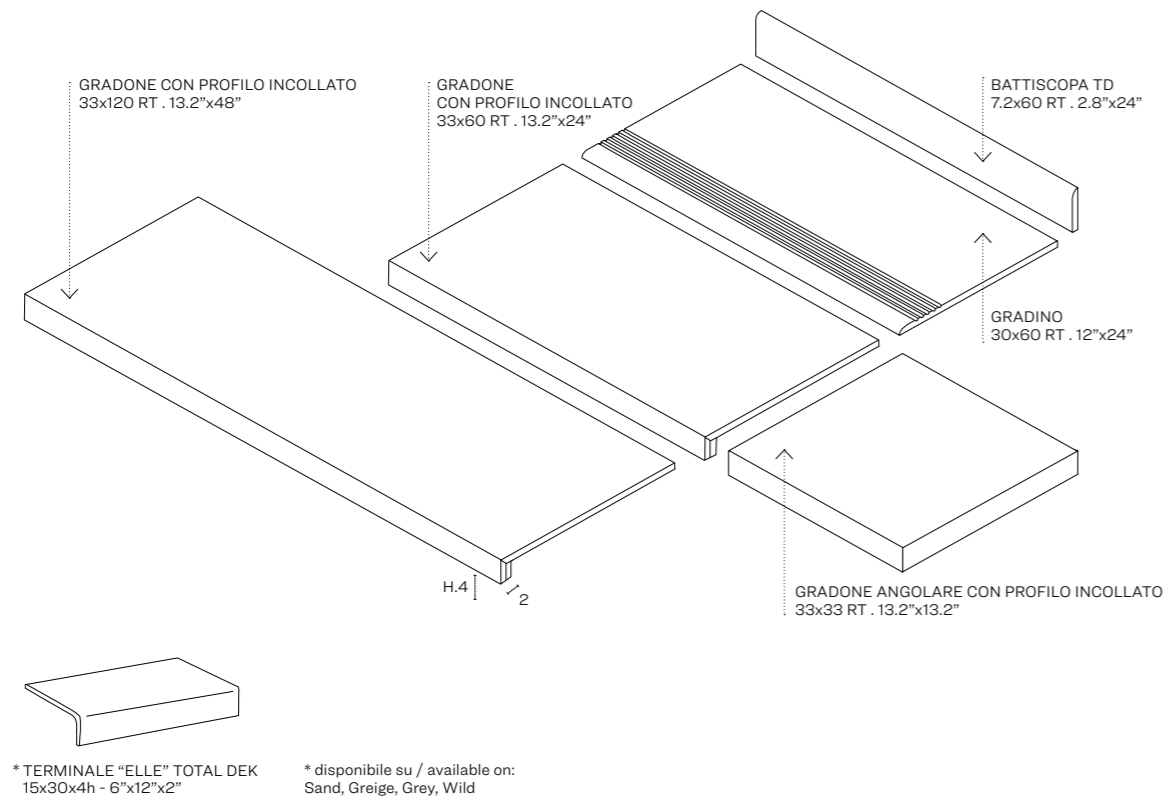

imballi | packing | emballage | Verpackung

	pz/box	mq/box	kg/box	box/plt	mq/plt	kg/plt	spessore
60x120RT antislip soft touch - grip	2	1,44	30,00	35	50,40	1062	9 mm
60x60RT antislip soft touch - grip	4	1,44	28,00	30	43,20	852	9 mm
30x60RT antislip soft touch - grip	7	1,26	25,00	40	50,40	1012	9 mm
22,5x45,3	13	1,325	22,80	40	53,00	924	8,5 mm
mosaico BRIK su rete 30x60RT	4	-	-	-	-	-	9 mm
mosaico TEN su rete 30x30RT	10	0,90	16,00	30	27,00	495	9 mm
mosaico PATTERN 3,5x60RT	4	-	-	-	-	-	9 mm
mosaico su rete 30x30RT	10	0,90	16,00	30	27,00	495	9 mm
gradone c/prof.inc. 33x120	2	-	-	-	-	-	-
gradone c/prof.inc. 33x60	4	-	-	-	-	-	-
ang.gradone c/prof.inc. 33x33	4	-	-	-	-	-	-
gradino 30x60RT	7	-	-	-	-	-	-
terminale a L TD	8	0,36	10,75	48	17,28	530	-
7,2x60 battiscopa TD	10	6 ml	9,40	70	420 ml	673	-
60x120 RT T_20	1	0,72	32,00	35	25,20	1135	20 mm
60x60RT T_20	2	0,72	32,00	30	21,60	972	20 mm

	9 mm 60x120 RT 24"x48"	9 mm 60x60 RT 24"x24"	9 mm 30x60 RT 12"x24"	8,5 mm 22,5x45,3 9"x18"
light	■ □	■ □	■ □	
sand	■ □ T.20	■ □ T.20	■ □	○
greige	■ □ T.20	■ □ T.20	■ □	○
grey	■ □ T.20	■ □ T.20	■ □	○
wild	■ □	■ □	■ □	○

- ANTI-SLIP SOFT TOUCH R10 B
- GRIP R11 C
- STRUTTURATO R11 C
- T.20 R11 C

AVVERTENZE PER LA POSA | RECOMMENDATIONS FOR INSTALLATION RECOMMANDATIONS POUR LA POSE | VERLEGETIPPS

Per la posa del materiale rettificato si prescrive una fuga minima di 2 mm . As for rectified materials, a minimum joint of 2 mm is required . Pour la pose du matériau rectifié, il faut réaliser un joint minimum de 2 mm . Für die Verlegung des geschliffenen Materials ist eine Mindestfuge von 2 mm vorgeschrieben.

Si raccomanda di posare i materiali sfalsati di 20 cm al massimo, mai a metà della loro lunghezza . It is strongly recommended to install the materials in a staggered pattern of a maximum of 20 cm, never at half way its length . Il est conseillé de poser les matériaux en décalé de 20 cm au maximum, jamais à la moitié de leur longueur . Es wird empfohlen, die Materialien um höchstens 20 cm versetzt zu verlegen und nie in der Mitte ihrer Länge

Ceramics. A safe choice.



IGIENICA Hygienic

La ceramica è facile da pulire, igienica e pratica; basta un semplice detergente neutro per rimuovere lo sporco e facilmente ritorna alla sua bellezza originaria.

Ceramic material is easy to clean, hygienic and practical; all it takes is a simple, neutral detergent to remove dirt and restore it to its original splendour.

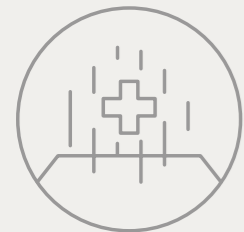

SALUBRE Healthy

Grazie alle sue caratteristiche fisiche la ceramica non rilascia alcuna sostanza nociva o VOC (sostanze organiche volatili) nell'ambiente in cui viviamo. Allo stesso modo non emette odori. Il gres porcellanato è privo di PVC, plastiche o derivati del petrolio.

Thanks to its physical characteristics, ceramic material does not release any harmful substances or VOC (volatile organic substances) into the environment we live in, nor does it give off odours. Porcelain tiles contain no PVC, plastic or petroleum derivatives.



RESISTENTE ALL'USURA Wear resistant

Il gres porcellanato è un materiale tecnico ultra compatto, altamente resistente all'usura; sopporta bene calpestio, urti, graffi e carichi pesanti.

Porcelain stoneware is an ultra-compact technical material, extremely resistant to wear, tread, shock, scratching and heavy loads.



RESISTENTE ALLE MACCHIE Stain resistant

La ceramica non teme macchie e non viene danneggiata con l'utilizzo di solventi e detersivi.

Ceramic material is resistant to stains and is not damaged by the use of solvents and detergents.



INGELIVA Frostproof

Il gres porcellanato resiste al gelo e a tutti gli attacchi degli agenti atmosferici, ed è quindi il prodotto ideale anche in ambienti esterni.

Porcelain stoneware is resistant to frost and to all kinds of attack from the elements, making it the ideal product also for outdoors.



PRODOTTO NEL RISPETTO DELL'AMBIENTE Eco-sustainable production

Il processo produttivo aziendale impiega un sistema di raccolta e di riutilizzo degli scarti di produzione, delle acque di lavorazione e del calore generato nelle fasi di produzione. In questo modo si limita il consumo di energia e di materie prime, per un'economia più sostenibile e un ridotto impatto ambientale.

The company's production process uses a system that collects and re-uses production waste, processing water and the heat generated during the production process, thus limiting the consumption of energy and raw materials, for a more sustainable economy and lower environmental impact.



RESISTENTE AI RAGGI UV Resistant to UV rays

Esposta al sole anche per lungo tempo la ceramica non cambia colore, e mantiene inalterate nel tempo le sue caratteristiche estetiche e tecniche.

Ceramic material does not fade even after lengthy exposure to sunlight, and maintains its aesthetic and technical characteristics over time.



PRODOTTO IGNIFUGO Fireproof

Resiste al fuoco e non emette fumi in seguito alla combustione.

Resistant to fire and does not emit smoke upon combustion.



IDEALE PER RISCALDAMENTO A PAVIMENTO Ideal for underfloor heating

Ottimo conduttore di calore, il gres porcellanato si scalda rapidamente e il calore è rilasciato immediatamente nell'ambiente; in questo modo consente di mantenere limitate temperature d'esercizio dell'impianto di riscaldamento.

An excellent conductor of heat, porcelain stoneware warms up quickly and releases heat into the air immediately, making it possible to keep the heating system working temperatures lower.



VERSATILE Versatile

La ceramica consente tante variazioni di stile e design, grazie all'ampia disponibilità di formati, spessori, finiture e tinte. Inoltre può essere utilizzata in qualsiasi ambiente, sia a pavimento che a rivestimento, in interno o esterno, in ambienti residenziali o pubblici.

All sorts of style and design variants are possible with ceramics, thanks to the wide availability of different sizes, thicknesses, finishes and colours. It can also be used anywhere, on both floors and walls, indoors or outdoors, in residential or public settings.

Sustainability

CERAMICHE SUPERGRES PER LA SOSTENIBILITÀ

La sostenibilità è un valore importante per noi.
Ci impegniamo attivamente nella tutela dell'ambiente,
promuovendo il benessere delle persone e valorizzando il territorio.

PRODUCT CERTIFICATIONS AND DECLARATIONS



PROCESS CERTIFICATIONS



RATING SYSTEMS



Sustainability is an important value for us.
A commitment to make a difference, creating a healthy and safe environment
where everyone can live, work, and thrive.



GRUPPO Bla

Norma di riferimento: EN 14411 (ISO 13006) Allegato G - Piastrelle di ceramica pressate a secco con basso assorbimento d'acqua (Ev 0,5%).
 Norme retenue: EN 14411 (ISO 13006) Annexe G - Carreaux céramiques pressés à sec avec faible absorption d'eau (Ev ≤ 0,5%).
 Besugznorm: EN 14411 (ISO 13006) Anlage G - Trockengepresste keramische Fliesen und Platten mit niedriger Wasseraufnahme (Ev ≤ 0,5%).
 Reference standard: EN 14411 (ISO 13006) Appendix G - Dry pressed ceramic tiles with low water absorption (Ev ≤ 0,5%).

CARATTERISTICHE TECNICHE . TECHNICAL CHARACTERISTICS Caracteristiques techniques . Technische eigenschaften	NORMA NORMS Normes Normen	REQUISITI RICHIESTI . REQUIREMENTS Conditions requisés . Geforderte eigenschaften			VALORE MEDIO SUPERGRES * Valeur moyenne . Average rating	
		N > 15 cm			SUPERFICIE ANTI SLIP SOFT TOUCH	SUPERFICIE GRIP
Lunghezza e larghezza dei lati . Lenght and width of the sides Longuer et largeur de côtés . Länge und Breite	ISO 10545-2	RETTIFICATI	± 0,3 %	± 1,0 mm	Conforme . According to Conforme . Gemäss	
Rettilinearità degli spigoli . Straightness Equerrage des angles . Kantengeradheit			± 0,3 %	± 0,8 mm	Conforme . According to Conforme . Gemäss	
Ortogonalità . Rectangularity Orthogonalité . Rechtwinkligkeit			± 0,3 %	± 1,5 mm	Conforme . According to Conforme . Gemäss	
Planarità . Flatness Planéité . Planität			± 0,6 mm ± 0,4 %	± 1,8 mm	Conforme . According to Conforme . Gemäss	
Spessore . Thickness Epaisseur . Stärke	ISO 10545-2	± 0,5 mm	± 5 %	± 0,5 mm	Conforme . According to Conforme . Gemäss	
Assorbimento % d'acqua . Water absorption Absorption d'eau . Wasseraufnahme	ISO 10545-3	Ev ≤ 0,5%			Conforme . According to Conforme . Gemäss	
Determinazione della resistenza a flessione e della forza di rottura Flexion and break resistance Résistance à la flexion et à la force de rupture Biegefestigkeit und Bruchlast	ISO 10545-4	Spessore ≥ 7,5 mm	$\left[\begin{array}{l} S \geq 1300 \\ R \geq 35 \text{ N/mm}^2 \end{array} \right.$		Conforme . According to Conforme . Gemäss	
Determinazione della resistenza all'abrasione profonda Deep Scratch Resistance Résistance à l'abrasion profonde Tiefenverschleissbeständigkeit	ISO 10545-6	≤ 175 mm ³			Conforme According to Conforme . Gemäss	
Coefficiente di espansione termica lineare tra 20° e 100° C Linear thermal expansion 20°C to 100°C Dilatation thermique linéaire entre 20°C et 100°C Lineare Waerme-ausdehnung zwischen 20°C und 100°C	ISO 10545-8	Metodo di prova disponibile . Test method available Méthode d'essai disponible . Prüfverfahren verfügbar			Conforme . According to Conforme . Gemäss	
Resistenza agli sbalzi termici . Thermal shock resistance Résistance aux écarts de Température . Temperaturwechselbeständigkeit	ISO 10545-9	Metodo di prova disponibile . Test method available Méthode d'essai disponible . Prüfverfahren verfügbar			Conforme . According to Conforme . Gemäss	
Resistenza al gelo . Frost resistance Résistance au gel . Frostbeständigkeit	ISO 10545-12	Metodo di prova disponibile . Test method available Méthode d'essai disponible . Prüfverfahren verfügbar			Conforme . According to Conforme . Gemäss	
Reazione al fuoco . Reaction to fire Réaction au feu . Brandverhalten	-	Classe A1 oppure A1 _{fl} - Class A1 or A1 _{fl} Categorie A1 ou A1 _{fl} - Klasse A1oder A1 _{fl}			A1-A1 _{fl}	
Determinazione della resistenza chimica . Chemical resistance Résistance chimique . Chemikalienbeständigkeit	ISO 10545-13	Classe B minimo Class B min Clase B min Klasse B min			A LA HA	
Determinazione della resistenza alle macchie Resistance to staining Résistance aux taches . Beständigkeit gegen Fleckenbil	ISO 10545-14	Classe 3 minimo . Class 3 min Clase 3 min . Klasse 3 min			Conforme . According to Conforme . Gemäss	
Resistenza allo scivolamento . Slip resistance Résistance au glissement . Bestimmung der Rutschemmungsfähigkeit	EN 16165 (previously DIN 51130)	Classificazione R . Classification R Evaluación R . Klassifizierung R			R10	R11
Resistenza allo scivolamento - superfici bagnate calpestio a piedi scalzi Résistance au glissement - surfaces mouillées passage à pieds nus Bestimmung der Rutschemmungsfähigkeit - nasse Oberfläche - Barfuß-gehen Coefficient of friction - dry surfaces walking on barefoot	EN 16165 (previously DIN 51097)	Classificazione A B C - Evaluación A B C Klassifizierung A B C - Classification A B C			B	C
Coefficiente di attrito dinamico Resistance de frottement dynamique Dynamischer reibungskoeffizient Dynamic friction coefficient	METODO B.C.R.A	D.M.I. Giugno 1989 n.236 (μ > 0,40)			Conforme According to Conforme Gemäss	Conforme According to Conforme Gemäss
Resistenza allo scivolamento - coefficiente di attrito dinamico (DCOF) Slip resistance - dynamic friction coefficient Résistance au glissement - resistance de frottement dynamique Bestimmung der Rutschemmungsfähigkeit - dynamischer reibungskoeffizient	ANSI A326.3-2017	≥ 0,42 wet			Conforme According to Conform Gemäss	Conforme According to Conforme Gemäss
GRADO DI VARIAZIONE CROMATICA Ogni prodotto si caratterizza per un grado di stonalizzazione variabile da prodotto a prodotto, da colore a colore. Per stonalizzazione s'intende variazione di gradazione cromatica da piastrella a piastrella. DEGRÉ DE VARIATION CROMATIQUE Chaque produit est caractérisé par un degré de nuance variable d'un produit à l'autre et d'une couleur à une autre. Par nuance, il faut entendre une variation de la gradation de couleur entre un carreau et un autre. GRAD DER FARBABWEICHUNG Jedes Produkt kennzeichnet sich durch einen bestimmten Grad an Marmorierung (Schattierung), der sich von Produkt zu Produkt, von Farbe zu Farbe unterscheiden kann. Unter Marmorierung versteht man den Grad der Farbänderung von Fliese zu Fliese. COLOUR SHADE VARIATION Every product is characterised by colour-shading that can vary from one product to another and from one colour to another. When referring to colour-shading we refer to the chromatic variation of the tile surface.		 Prodotto con marcata variazione cromatica Product with a marked chromatic variation Produit avec une variation de couleur marquée Produkt mit deutlicher Farbveränderung				

Disclaimer:

I dati e le informazioni riportate nel presente catalogo sono aggiornate al momento della stampa e potrebbero subire successive correzioni e/o modifiche.
 Verificare sempre l'ultima edizione disponibile confrontando la data riportata nell'ultima pagina della versione cartacea, con quella indicata nel pdf del catalogo scaricabile dal sito www.supergres.com

I colori e le caratteristiche estetiche dei prodotti sono indicativi e si avvicinano quanto più possibile a quelli reali nei limiti consentiti dai processi di stampa.

Data and information reported in this catalogue are updated at the moment of catalogue printing therefore they may be subject to subsequent corrections and/or amendments. Always check the latest available issue and compare the date reported on the last page of the hard-paper copy of the catalogue with that stated in the pdf. format downloadable on website www.supergres.com

The colours and aesthetic features of products are indicative and reproduce, as close as possible, the real colours and features taking into consideration the restrictions of printing processes.

Finito di stampare a Modena (MO) nel mese di aprile 2025 per conto di Ceramiche Supergres - Strada Statale 467, n° 34 - 42013 Casalgrande (RE) Italy

I prodotti, i marchi e le immagini riprodotte nel presente catalogo sono tutelati ai sensi della normativa vigente in materia di proprietà intellettuale. Ogni violazione degli stessi verrà perseguita a norma di legge.

Printed in Modena (MO) in the month of April 2025 by on behalf of Ceramiche Supergres - Strada Statale 467, n° 34 - 42013 Casalgrande (RE) Italy

All products, trade-marks and photographs reproduced in this catalogue are subject to all existing intellectual property laws. Any breach thereof will be dealt with under the provisions provided by such law.

© Copyright 2025 Ceramiche Supergres Casalgrande (Reggio Emilia) - Italy
 Pubblicato da Ceramiche Supergres. Strada Statale 467, n° 34 - 42013 Casalgrande (RE) Italy - Aprile 2024
 Progetto, direzione e coordinamento a cura dell'ufficio marketing Ceramiche Supergres

© Copyright 2025 by Ceramiche Supergres Casalgrande (Reggio Emilia) - Italy
 Published by Ceramiche Supergres. Strada Statale 467, n° 34 - 42013 Casalgrande (RE) Ital - April 2024
 Project, management and co-ordination by marketing Ceramiche Supergres

Office
Strada Statale 467, 34
42013 Casalgrande (RE) Italy
Ph. +39 0522 997411
Fax Export +39 0522 997415
Fax Italia +39 0522 997494

Warehouse
Via dell'Industria, 1 - Villaggio Macina
42013 Salvaterra di Casalgrande (RE) Italy

info@supergres.com
www.supergres.com

CERAMICHE
SUPERGRES